

C.I.P.**44 S&W Special**

Ursprungsland: US

TAB. IV

Datum 84-06-14

Revision 00-06-07

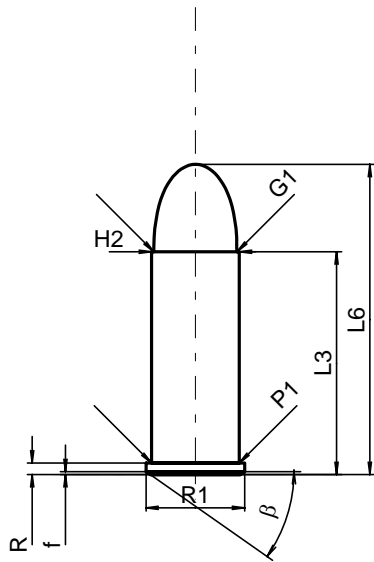
**PATRONE MAXI****Längen**

L1	=	
L2	=	
L3 ¹⁾	=	29.46
L4	=	
L5	=	
L6	=	41.02

Hülsenboden

R ¹⁾	=	1.52	-0.25
R1	=	13.06	
R3	=		
E	=		
E1	=		
e min	=		
delta	=		
f	=	0.40	
beta	=	35°	

Pulverkammer

P1	=	11.60
P2	=	

Schulterkonus

alpha	=	
S	=	
r1 min	=	
r2	=	

Hülsenhals

H1	=	
H2 ¹⁾	=	11.60

Geschoss

G1 ¹⁾	=	10.98
G2	=	
F	=	
L3+G ¹⁾	=	43.26

Drücke (Energien)**Mech. elektr. Wandler**

Pmax	=	1000 bar
PK	=	1150 bar
PE	=	1300 bar
M	=	17.50

Verschiedene Daten

Fe ¹⁾	=	0.25
delta L	=	

PATRONENLAGER MINI**Längen**

L1	=	
L2	=	
L3 ¹⁾	=	30.06

Stoßboden

R ¹⁾	=	1.52
R1	=	13.16
R2	=	
R3	=	
r	=	

Pulverkammer

E	=	
P1 ¹⁾	=	11.66
P2	=	

Schulterkonus

alpha	=	
S	=	
r1 max	=	
r2	=	

Hülsenhals

H1	=	
H2 ¹⁾	=	11.63

Geschossübergang

G1 ^{1)*}	=	10.99
G ¹⁾	=	13.80
alpha [*]	=	22°12'50"
h	=	1.63
s	=	11.51
i ^{1)*}	=	5°
w	=	

Lauf

F ^{1)*}	=	10.59
Z ¹⁾	=	10.90

Züge

b	=	3.26
N	=	5
u	=	508.00
Q	=	90.65 mm ²

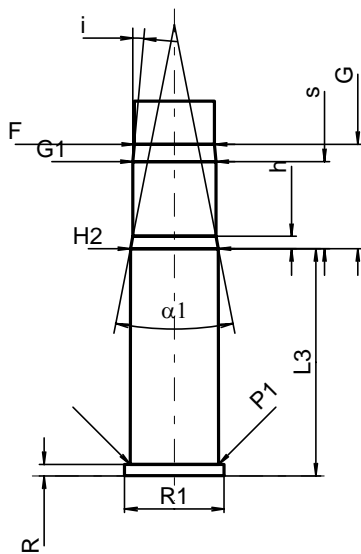

Maßstab 1:1

Maße in << mm >>
Maße und Toleranzen für Messläufe
siehe Anhang CR 1.

Bemerkungen: 1) Kontrolle aus Sicherheitsgründen
* Grundmaße